

Power Transducer Series LT-UNIT

WATT TRANSDUCER

Functions & Features

- Provides a DC output signal and a pulse totalizer signal in proportion to AC active power
- Convenient pulse unit output (Wh×10ⁿ)
- Measuring bidirectional power flow
- DC output containing little ripple is ideal for computer input
- "Time division multiplication" method accepts distorted waveforms
- Isolation up to 2000 V AC
- High-density mounting
- Conforms to IEC 60688

Typical Applications

- Centralized monitoring and control of power management system in a manufacturing facility or building
- SCR - Silicon Controlled Rectifier

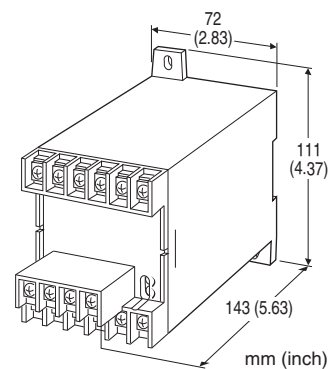

MODEL: LTWT-[1][2][3][4][5]-[6][7]

ORDERING INFORMATION

- Code number: LTWT-[1][2][3][4][5]-[6][7]
- Specify a code from below for each of [1] through [7].
(e.g. LTWT-115A2-R/T/Q)
- Special output range (For codes Z & 0)
- Specify the specification for option code /Q
(e.g. /C01)
- Use Ordering Information Sheet (No. ESU-3355).

How to determine Pulse Unit

[Example]

3-phase / 3-wire, VT 3300/110 V, CT 250/5 A,
calibration range 750 W

$$10 \text{ [kWh/pulse]} \div ((3300 \div 110) \times (250 \div 5))$$

$$= 6.666 \times 10^{-3} \text{ [kWh/pulse]}$$

$$= 6.666 \text{ [Wh/pulse]}$$

Check that the required pulse unit is within the available frequency range, 0.006 – 3.12 Hz.

$$\text{Input Range [W]} \div (\text{Calculated Pulse} \times 3600 \text{ [s]})$$

$$= 750 \div (6.666 \times 3600)$$

$$= 0.03125 \text{ [Hz]}$$

[1] CONFIGURATION

- 1: 3-phase / 3-wire
- 2: Single-phase / 2-wire
- 3: Single-phase / 3-wire
- 4: 3-phase / 4-wire

[2] VT INPUT (unbalanced load)

For 3-phase / 4-wire, phase voltages (e.g. 110 V / $\sqrt{3}$) are used.

- 1: 100, 110, 115, 120 V AC
(Not selectable for single-phase / 3-wire system.)
 - 2: 190, 200, 210, 220, 230, 240 V AC
(Not selectable for single-phase / 3-wire system.)
 - 4: 380, 400, 415, 430, 440, 480 V AC
(Not selectable for single-phase / 3-wire system.)
- A: 100 V / 200 V AC
(single-phase / 3-wire only)

[3] CT INPUT (unbalanced load)

Current

- 1: 1 A AC
- 2: 2 A AC
- 5: 5 A AC

[4] DC OUTPUT

Current

- A: 4 - 20 mA DC (Load resistance 500 Ω max.)
 D: 0 - 20 mA DC (Load resistance 500 Ω max.)
 F: 0 - 10 mA DC (Load resistance 1000 Ω max.)
 G: 0 - 1 mA DC (Load resistance 10 k Ω max.)
 J: 0 - 5 mA DC (Load resistance 2000 Ω max.)
 FW: -10 - +10 mA DC (Load resistance 1000 Ω max.)
 GW: -1 - +1 mA DC (Load resistance 10 k Ω max.)
 JW: -5 - +5 mA DC (Load resistance 2000 Ω max.)
 Z: Specify current (See OUTPUT SPECIFICATIONS)

Voltage

- 1: 0 - 10 mV DC (Load resistance 10 k Ω min.)
 - 2: 0 - 100 mV DC (Load resistance 100 k Ω min.)
 - 3: 0 - 1 V DC (Load resistance 1000 Ω min.)
 - 4: 0 - 10 V DC (Load resistance 10 k Ω min.)
 - 5: 0 - 5 V DC (Load resistance 5000 Ω min.)
 - 6: 1 - 5 V DC (Load resistance 5000 Ω min.)
- 1W: -10 - +10 mV DC (Load resistance 10 k Ω min.)
 2W: -100 - +100 mV DC (Load resistance 100 k Ω min.)
 3W: -1 - +1 V DC (Load resistance 1000 Ω min.)

4W: -10 – +10 V DC (Load resistance 10 kΩ min.)
5W: -5 – +5 V DC (Load resistance 5000 Ω min.)
0: Specify voltage (See OUTPUT SPECIFICATIONS)

[5] PULSE OUTPUT (open collector)

0: None
1: 2.777 Hz at 100 % input
2: Specify pulse unit (within 0.006 – 3.12 Hz)

[6] AUXILIARY POWER SUPPLY

AC Power

K3: 100 – 120V AC
 (Operational voltage range 85 - 132 V, 47 - 66 Hz)

L3: 200 – 240V AC
 (Operational voltage range 170 - 264 V, 47 - 66 Hz)

DC Power

R: 24 V DC
 (Operational voltage range 24 V ±10 %, ripple 10 %p-p max.)

V: 48 V DC
 (Operational voltage range 48 V ± 10 % , ripple 10 % p-p max.)

P: 110 V DC
 (Operational voltage range 85 – 150 V, ripple 10 %p-p max.)
 (CE not available)

[7] OPTIONS (multiple selections)

Terminal Cover

blank: Without

/T: With

Custom specification

(Refer to the custom specification list for difference of specification and combination of code numbers.)

blank: none

/X1: Input range

/X2: Input span

Other Options

blank: none

/Q: Option other than the above (specify the specification)

SPECIFICATIONS OF OPTION: Q

COATING (For the detail, refer to M-System's web site.)

/C01: Silicone coating

/C02: Polyurethane coating

/C03: Rubber coating

GENERAL SPECIFICATIONS

Connection: M4 screw terminals (torque 1.2 N·m)

Screw terminal: Chrome-plated steel

Housing material: Flame-resistant resin (black)

Isolation: Voltage input to current input to DC output to pulse output to auxiliary power

Computation: Time division multiplication

Overrange output: Approx. -10 to +120 % at 1 – 5 V

Zero adjustment(DC output): -5 to + 5 % (front)

Span adjustment(DC output): 95 to + 105 % (front)

INPUT SPECIFICATIONS

Frequency: 50 or 60 Hz

• Voltage input

Operational range: 0 – 120 % of rating

Overload capacity: 200 % of rating for 10 sec., 120 % continuous

• Current input

Operational range: 0 – 120 % of rating

Overload capacity: 4000 % of rating for 1 sec., 2000 % for 4 sec., 120 % continuous

■ How to determine Wattage Range

Calibration Range [W] = Measuring Wattage ÷ ((VT Ratio) × (CT Ratio))

Check that the required calibration range is within the available range in the table. Specify this range when ordering.

[Example]

3-phase / 3-wire, measuring wattage 750 kW,

VT 3300/110 V, CT 250/5 A

$750 \times 10^3 [W] \div ((3300 \div 110) \times (250 \div 5)) = 500 [W]$

• Single-phase / 2-wire

INPUT		USABLE RANGE	BURDEN (VA)	
VT/CT CODE	STD.RANGE		VT	CT
1/1	±100 W	±50 – ±120 W	0.2	0.1
1/2	±200 W			0.2
1/5	±500 W			0.5
2/1	±200 W	±100 – ±240 W	0.4	0.1
2/2	±400 W			0.2
2/5	±1000 W			0.5
4/1	±400 W	±200 – ±480 W	0.6	0.1
4/2	±800 W			0.2
4/5	±2000 W			0.5

• Single-phase / 3-wire

INPUT		USABLE RANGE	BURDEN (VA)	
VT/CT CODE	STD.RANGE		VT	CT
A/1	±200 W	±100 – ±240 W	0.2 /phase	0.1/ph
A/2	±400 W			0.2/ph
A/5	±1000 W			0.5/ph

• 3-phase / 3-wire

INPUT		USABLE RANGE	BURDEN (VA)	
VT/CT CODE	STD.RANGE		VT	CT
1/1	±200 W	±100 – ±240 W	0.2 /phase	0.1/ph
1/2	±400 W			0.2/ph
1/5	±1000 W			0.5/ph
2/1	±400 W	±200 – ±480 W	0.4 /phase	0.1/ph
2/2	±800 W			0.2/ph
2/5	±2000 W			0.5/ph
4/1	±800 W	±400 – ±960 W	0.6 /phase	0.1/ph
4/2	±1600 W			0.2/ph
4/5	±4000 W			0.5/ph

• 3-phase / 4-wire

INPUT		USABLE RANGE	BURDEN (VA)	
VT/CT CODE	STD.RANGE		VT	CT
1/1	±200 W	±100 – ±240 W	0.1 /phase	0.1/ph
1/2	±400 W			0.2/ph
1/5	±1000 W			0.5/ph
2/1	±400 W	±200 – ±480 W	0.3 /phase	0.1/ph
2/2	±800 W			0.2/ph
2/5	±2000 W			0.5/ph
4/1	±800 W	±400 – ±960 W	0.4 /phase	0.1/ph
4/2	±1600 W			0.2/ph
4/5	±4000 W			0.5/ph

OUTPUT SPECIFICATIONS

■ DC Output

• DC Current: -10 - +20 mA DC

Span: Min. 1 mA, max. 20 mA

Offset: Max. 1.5 times span

Load resistance: Output drive 10 V max.

• DC Voltage: -10 - +12 V DC

Minimum span: 5 mV

Offset: Max. 1.5 times span

Load resistance: Output drive 1 mA max. at ≥ 0.5 V

■ Pulse output: Open collector

0 Hz at 0 W (cutout at approx. 0.5 - 1.0 %)

Rating: 35 V DC @ 100 mA

ON voltage: ≤ 1 V at 100 mA

ON duration: Max. 0.5 sec., min. 50 msec. (approx.)

Frequency range: 0 - 2.777 Hz (0 - 100 %) standard; 0 - 0.006 Hz through 3.12 Hz is possible.

• 2.777 Hz at 100 % Input

[Example] 1000 W calibration range

2.777 [Hz] × 3600 [s] ÷ 1 [kW] = 10000 [pulses/kWh]

• Specified Pulse Unit: Refers to how much electrical energy (kWh) consumption at the primary of the VT and CT corresponds to the single output pulse per hour from the transducer.

■ OPERATION DIAGRAM (example)

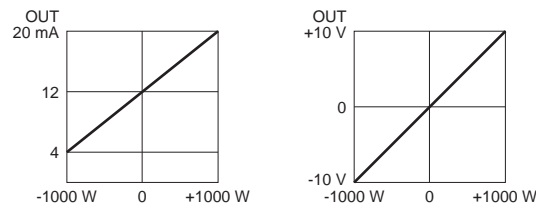
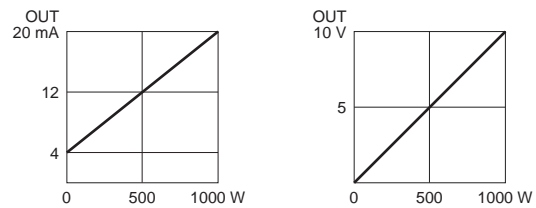

INSTALLATION

Power Consumption

• AC: Approx. 2 VA

• DC: Approx. 2 W (18 mA at 110 V)

Operating temperature: -10 to +55°C (14 to 131°F)

Operating humidity: 30 to 85 %RH (non-condensing)

Mounting: Surface or DIN rail

Weight: 450 g (0.99 lb)

PERFORMANCE in percentage of span

Accuracy: ±0.5 % (at 23°C ±10°C or 73.4°F ±18°F, 45 - 65 Hz)

Magnetic field (ext. origin) effect: ± 0.5 % (400 A/m)

Response time: ≤ 2 sec. (0 - 100 % ±1 %)

Ripple: 0.5 %p-p max. (The output ripple may increase when there is great difference between the frequencies of input signal and power supply)

Line voltage effect: ±0.25 % over operational voltage range (Operational voltage range is [K3: 90 to 132 V AC], [L3: 180 to 264 V AC] when the DC output code is 4W or the specified voltage is ≤ -9 V)

Insulation resistance: ≥ 100 MΩ with 500 V DC

Dielectric strength: 2000 V AC @ 1 minute

(voltage input to current input to DC output to pulse output
to auxiliary power to ground)

Impulse withstand voltage: 1.2 / 50 μ sec., \pm 5 kV

(input to output or ground)

STANDARDS & APPROVALS

EU conformity:

EMC Directive

EMI EN 61000-6-4

EMS EN 61000-6-2

Low Voltage Directive

EN 61010-1

Measurement Category II (input)

Installation Category II (auxiliary power)

Pollution Degree 2

Input to output or auxiliary power: Reinforced insulation
(550 V)

Output to auxiliary power: Reinforced insulation (300 V)

RoHS Directive

CONNECTION DIAGRAM

■ 3-PHASE/3-WIRE

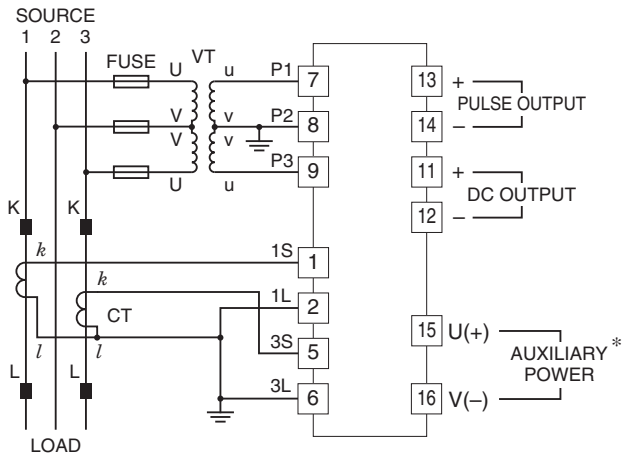

■ SINGLE-PHASE/2-WIRE

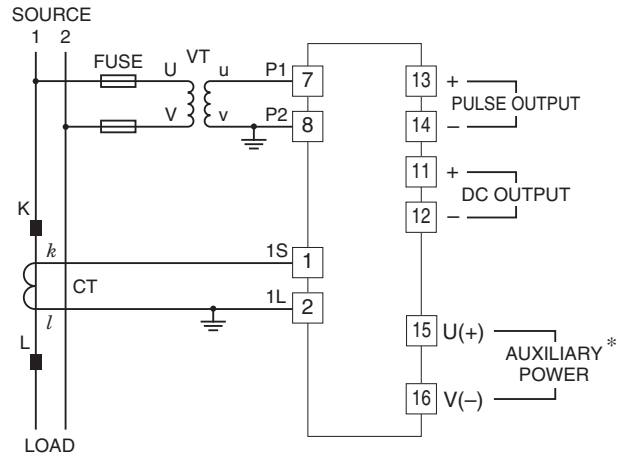

■ SINGLE-PHASE/3-WIRE

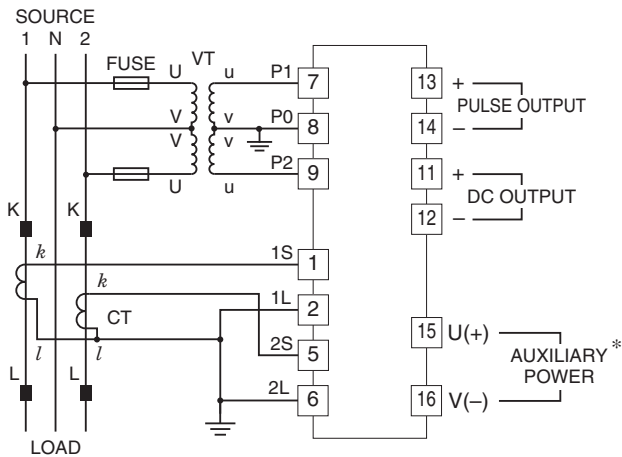

■ 3-PHASE/4-WIRE

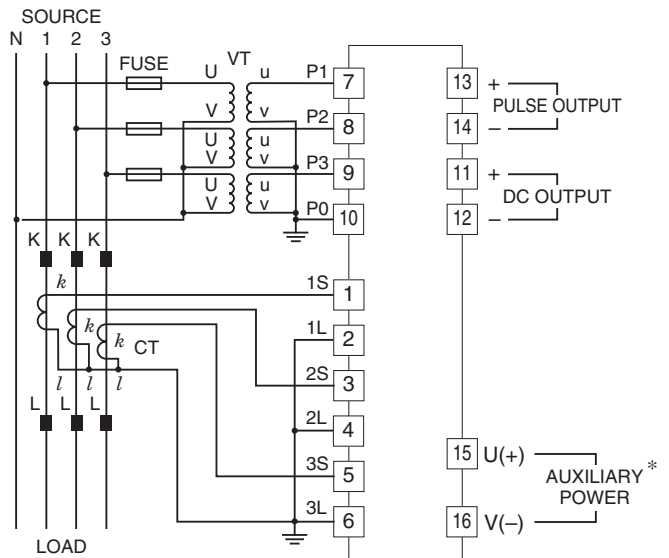

Pulse Output Connection Example

■ Open Collector

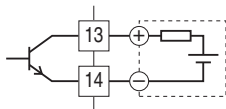

* The transducer can be powered from the input voltage when the voltage is sufficiently stable and meets within the range of auxiliary power supply of the unit specified in the data sheet/instruction manual.

EXTERNAL DIMENSIONS & TERMINAL ASSIGNMENTS unit: mm [inch]

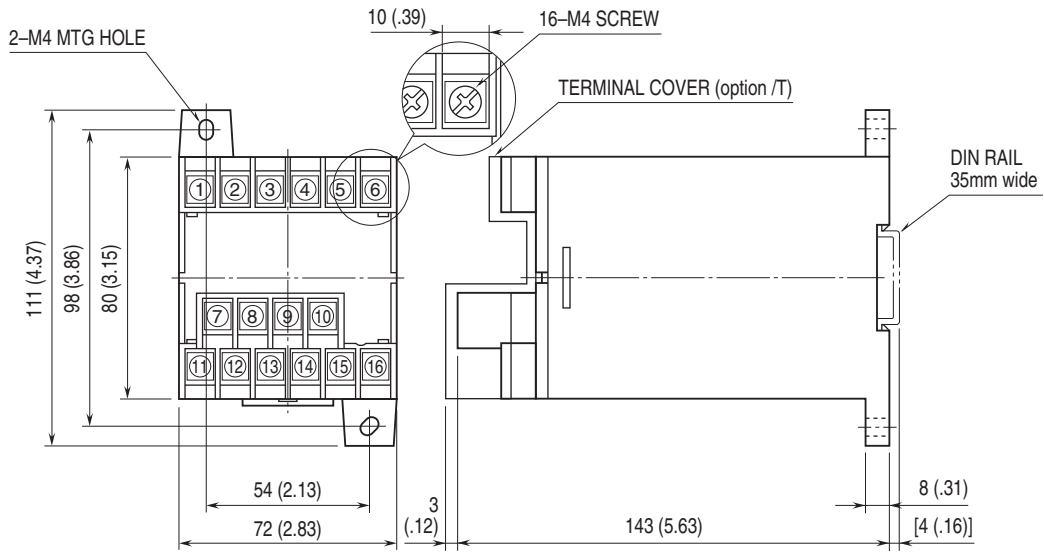

• When mounting, no extra space is needed between units.



Specifications are subject to change without notice.

CUSTOM SPECIFICATION LIST

Refer to the following pages for each detailed custom specification.

Custom specification: Option /X1

■ Major specification changes

Input 0%: -65 - 0 % of input 100% (W)

Custom specification: Option /X2

■ Major specification changes

Input span: 10 - 50 % for input span of standard input range

CUSTOM SPECIFICATION : OPTION /X1

Major specification changes

Input 0%: -65 - 0 % of input 100% (W)

MODEL: LTWT-[1][2][3][4][5]-[6][7]/X1

Same as standard specification (without customization) except followings.

Refer to standard specification pages.

ORDERING INFORMATION

- Code number: LTWT-[1][2][3][4][5]-[6][7]/X1
- For each of [1] through [7] same code as standard specification is available.
- Use Ordering Information Sheet (No. ESU-3355).
- (e.g. LTWT-115A0-R/T/X1)
- Refer to standard specification pages.

SPECIFICATION CHANGES

■ Input specifications

- Available input range

The value for 0% is within -65 - 0 % of input 100%.

e.g. Input range: -75 to 1000 [W]

$$-75 [W] \div 1000 [W] \times 100 = -7.5 [\%]$$

■ Standards & approval

- CE not available

■ OPERATION DIAGRAM (example)

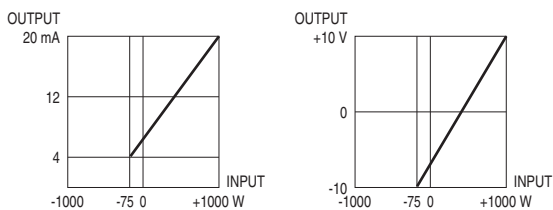

CUSTOM SPECIFICATION : OPTION /X2

Major specification changes

Input span: 10 - 50 % of input span of std. input range

MODEL: LTWT-[1][2][3][4][5]-[6][7]/X2

Same as standard specification (without customization) except followings.

Refer to standard specification pages.

ORDERING INFORMATION

- Code number: LTWT-[1][2][3][4][5]-[6][7]/X2
- For each of [1] through [7] same code as standard specification is available.
- Use Ordering Information Sheet (No. ESU-3355).
- (e.g. LTWT-115A0-R/T/X2)
- Refer to standard specification pages.

SPECIFICATION CHANGES

- Input specifications
 - Available input range: Refer to the table shown right.
- PERFORMANCE

Accuracy (including influence from temperature and frequency): Refer to the table shown right.

e.g. 3-phase / 3-wire, 100 V, 5 A

Input range: -350 - +350 W

As input span is 35 % for std. range (-1000 - +1000 W), accuracy is ± 0.8 %.
- Standards & approval
 - CE not available

• INPUT RANGE

CONFIGURATION	VT/CT CODE	STD. RANGE	USABLE RANGE
Single-phase/ 2-wire	1/1	± 100 W	$\pm 10 - \pm 50$ W
	1/2	± 200 W	$\pm 20 - \pm 100$ W
	1/5	± 500 W	$\pm 50 - \pm 250$ W
	2/1	± 200 W	$\pm 20 - \pm 100$ W
	2/2	± 400 W	$\pm 40 - \pm 200$ W
	2/5	± 1000 W	$\pm 100 - \pm 500$ W
	4/1	± 400 W	$\pm 40 - \pm 200$ W
	4/2	± 800 W	$\pm 80 - \pm 400$ W
	4/5	± 2000 W	$\pm 200 - \pm 1000$ W
Single-phase/ 3-wire	A/1	± 200 W	$\pm 20 - \pm 100$ W
	A/2	± 400 W	$\pm 40 - \pm 200$ W
	A/5	± 1000 W	$\pm 100 - \pm 500$ W
3-phase/3-wire	1/1	± 200 W	$\pm 20 - \pm 100$ W
3-phase/4-wire	1/2	± 400 W	$\pm 40 - \pm 200$ W
	1/5	± 1000 W	$\pm 100 - \pm 500$ W
	2/1	± 400 W	$\pm 40 - \pm 200$ W
	2/2	± 800 W	$\pm 80 - \pm 400$ W
	2/5	± 2000 W	$\pm 200 - \pm 1000$ W
	4/1	± 800 W	$\pm 80 - \pm 400$ W
	4/2	± 1600 W	$\pm 160 - \pm 800$ W
	4/5	± 4000 W	$\pm 400 - \pm 2000$ W

• ACCURACY

INPUT SPAN	ACCURACY
$\geq 10 - < 25\%$ of std. range	$\pm 1.5\%$
$\geq 25 - < 30\%$ of std. range	$\pm 1.0\%$
$\geq 30 - < 35\%$ of std. range	$\pm 0.9\%$
$\geq 35 - < 40\%$ of std. range	$\pm 0.8\%$
$\geq 40 - < 45\%$ of std. range	$\pm 0.7\%$
$\geq 45 - < 50\%$ of std. range	$\pm 0.6\%$