

Hybrid IC Isolation Amplifiers 20 Series

Input bias current: 15 nA TYP. (@25°C)

ISOLATION AMPLIFIER

(output isolation)

Functions & Features

- Being used for printed wiring board installation
- Isolating between input and output, output and power
- Built in surge protectors
- Isolation between input and output up to 2000 V AC
- Power 15 V DC

Typical Applications

- Isolating the fields and output circuit of microprocessor to reduce common mode noise
- Available for manufacturers of small-lot products to omit the development of isolation circuit

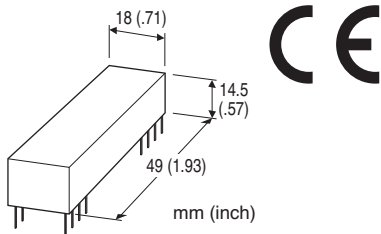

MODEL: 20VS2-2-U

ORDERING INFORMATION

- Code number: 20VS2-2-U

INPUT RANGE -10 - +10 V DC

OUTPUT RANGE -10 - +10 V DC

POWER INPUT

DC Power

U: 15 V DC

GENERAL SPECIFICATIONS

Construction: Hybrid IC

Housing material: Flame-resistant resin (black)

Isolation: Output or reference voltage source to input or power supply

INPUT SPECIFICATIONS

■ **DC Voltage**

Input : -10 - +10 V DC

Input resistance: $\geq 1 \text{ M}\Omega$ (10 k Ω in power failure)

Overload input voltage: 30 V DC continuous

Input offset voltage: $\pm 15 \text{ mV}$

OUTPUT SPECIFICATIONS

■ **DC Voltage:** -10 - +10 V DC

Load resistance: $\geq 2 \text{ k}\Omega$

Output impedance: $\leq 1 \Omega$

REFERENCE VOLTAGE SOURCE

Output voltage: $\pm 15 \text{ V DC} \pm 5 \%$

Load current: $\leq 5 \text{ mA}$

INSTALLATION

Power input

• **DC:** Operational voltage range: Rating $\pm 2 \%$; approx. 10 mA with no load; ripple 2 %p-p max.

Operating temperature: 0 to 60°C (32 to 140°F)

Operating humidity: 30 to 90 %RH (non-condensing)

Mounting: Soldering to the printed wiring board

Weight: 20 g (0.71 oz)

PERFORMANCE in percentage of span

Linearity: $\pm 0.05 \%$

Temp. coefficient:

Offset drift 40 ppm/°C

Span drift 50 ppm/°C

Frequency characteristics: Approx. 1 kHz, -3 dB

Response time: $\leq 450 \mu\text{sec}$. (0 - 90 %)

Conversion gain: $\times 1 \pm 1 \%$

Line voltage effect: $\pm 0.05 \%$ over voltage range

Insulation resistance: $\geq 100 \text{ M}\Omega$ with 500 V DC

Dielectric strength: 2000 V AC @ 1 minute

(output or reference voltage source to input or power supply)

STANDARDS & APPROVALS

EU conformity:

EMC Directive

EMI EN 61000-6-4

EMS EN 61000-6-2

RoHS Directive

EXTERNAL DIMENSIONS & TERMINAL ASSIGNMENTS unit: mm (inch)

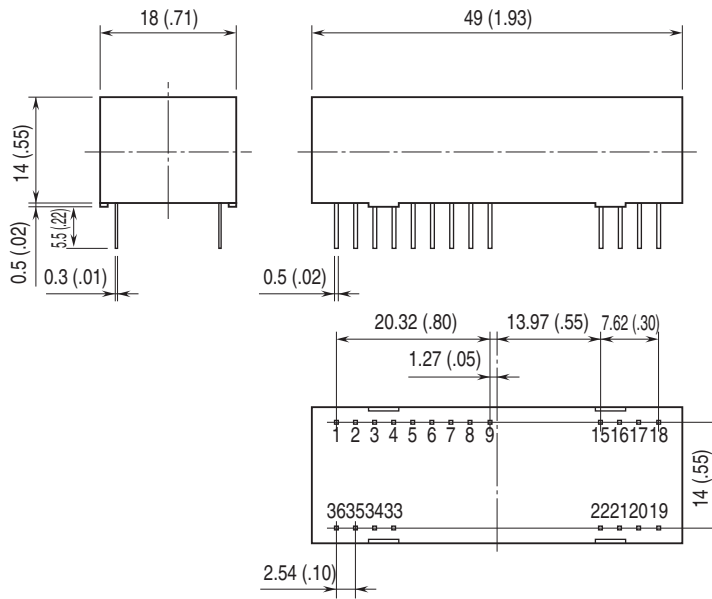

SCHEMATIC CIRCUITRY & CONNECTION DIAGRAM

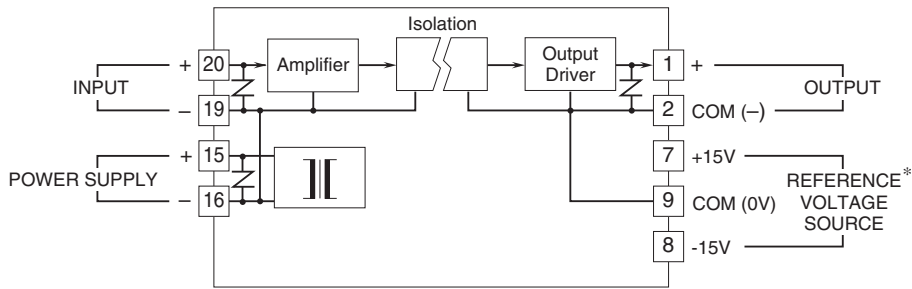

*To be used in the printed wiring board on which the unit is mounted.

APPLICATION EXAMPLE

External circuit of zero/span adjustment

Input: $\pm 10V$ DC

Output: $\pm 10V$ DC

Zero adjustments: approx. -1.0 – +1.0%

Span adjustments: approx. 99 – 101%

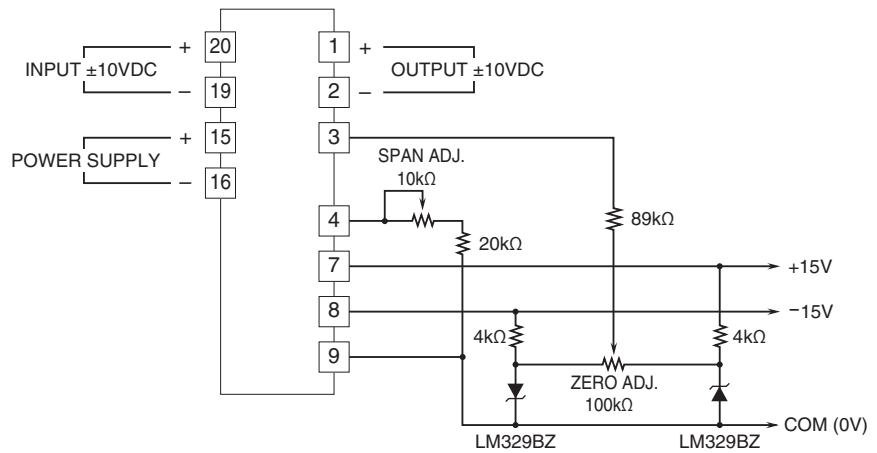

Specifications are subject to change without notice.