

BEFORE USE

Thank you for choosing M-System. Before use, please check contents of the package you received as outlined below.

If you have any problems or questions with the product, please contact M-System's Sales Office or representatives.

■ PACKAGE INCLUDES:

Totalized pulse input module(1)

■ MODEL NO.

Confirm Model No. marking on the product to be exactly what you ordered.

■ INSTRUCTION MANUAL

This manual describes necessary points of caution when you use this product, including installation, connection and basic maintenance procedures.

POINTS OF CAUTION**■ POWER INPUT RATING & OPERATIONAL RANGE**

- Locate the power input rating marked on the product and confirm its operational range as indicated below:
24V AC rating: 24V \pm 10%, 50/60 Hz, approx. 75mA
24V DC rating: 24V \pm 10%, approx. 40mA

■ GENERAL PRECAUTIONS

- Before you remove the unit or mount it, turn off the power supply and input signal for safety.

■ ENVIRONMENT

- Indoor use.
- When heavy dust or metal particles are present in the air, install the unit inside proper housing with sufficient ventilation.
- Do not install the unit where it is subjected to continuous vibration. Do not subject the unit to physical impact.
- Environmental temperature must be within -10 to +55°C (14 to 131°F) with relative humidity within 30 to 90% RH in order to ensure adequate life span and operation.

■ WIRING

- Do not install cables close to noise sources (relay drive cable, high frequency line, etc.).
- Do not bind these cables together with those in which noises are present. Do not install them in the same duct.

■ AND

- The unit is designed to function as soon as power is supplied, however, a warm up for 10 minutes is required for satisfying complete performance described in the data sheet.

COMPONENT IDENTIFICATION

■ SIDE VIEW

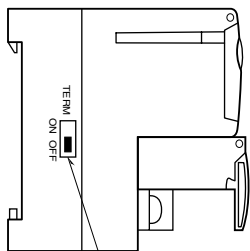

(I) Terminating Resistor SW

■ FRONT VIEW

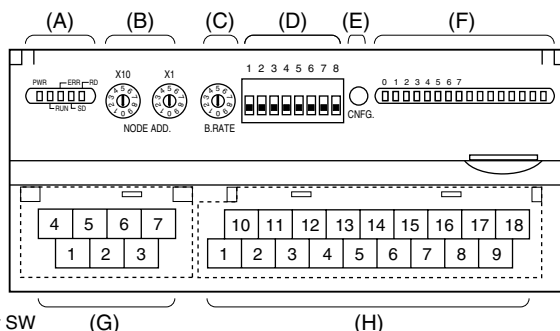

- (A) Status Indicator LED
- (B) Node Address Setting Rotary SW
- (C) Baud Rate Setting Rotary SW
- (D) Operating Mode Setting DIP SW (SW1)
- (E) PC Configurator Jack
- (F) Totalized Pulse Input Status Indicator LED
- (G) Modbus, Power Supply Terminals
- (H) Input Terminals
- (I) Terminating Resistor SW

■ STATUS INDICATOR LED

ID	COLOR	FUNCTION
PWR	Red	Turns on when the internal 5V is supplied normally.
RUN	Red	Turns on when the refresh data is received normally.
ERR	Red	Turns on when the received data is abnormal. Blinks when setting is abnormal.
SD	Red	Turns on when the module is transmitting.
RD	Red	Turns on when the module is receiving.

■ NODE ADDRESS

Node Address is selected between 1 and 99 in decimal. The left switch determines the tenths place digit, while the right switch does the ones place digit of the address.

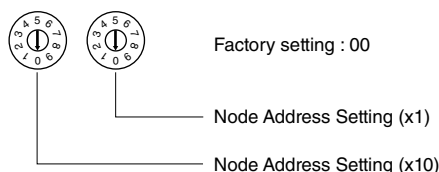

■ BAUD RATE

Baud Rate is selected with the rotary switch. (Factory setting: 0)

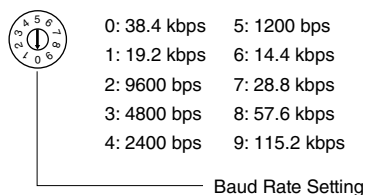

■ USER CONFIGURATION ITEMS

With PC configurator software (model: R7CON)

- Count range reset
- Number to reset at overflow
- Maximum count value

■ OPERATING MODE

• Extension (SW1-1, 1-2)

SW1-1	SW1-2	EXTENSION
OFF	OFF	No extension (*)
ON	OFF	Discrete input 8 or 16 points
OFF	ON	Discrete output 8 or 16 points

(*) Factory setting

Note: Be sure to set unused SW1-3 through 1-8 to OFF.

■ POWER SUPPLY, MODBUS TERMINAL ASSIGNMENT

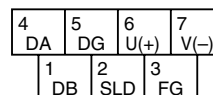

- (1) DB -
- (2) SLD Shield
- (3) FG FG
- (4) DA -
- (5) DG -
- (6) U(+) Power input
- (7) V(-) Power input

■ INPUT TERMINAL ASSIGNMENT

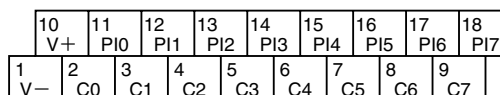

NO.	ID	FUNCTION	NO.	ID	FUNCTION
1	V-	Power (-)	10	V+	Power (+)
2	C0	Common	11	PI0	Input 0
3	C1	Common	12	PI1	Input 1
4	C2	Common	13	PI2	Input 2
5	C3	Common	14	PI3	Input 3
6	C4	Common	15	PI4	Input 4
7	C5	Common	16	PI5	Input 5
8	C6	Common	17	PI6	Input 6
9	C7	Common	18	PI7	Input 7

■ EXTENSION MODULE

Combinations with all extension modules are selectable.

■ PULSE INPUT STATUS INDICATOR LED

Totalized pulse modules have LED indicators showing input signal status.

- ON : LED ON
- OFF : LED OFF

DATA ACQUISITION & SETTING

R7M-PA8 data is allocated as described on the table below. Write the data on the corresponding area for reading data. The integrated value of each channel is a non-signed 2-word integer. Be sure to perform writing and reading by 2 word units. The return value at overflow is "0" or "1" (default setting: 0). The maximum range available is 1 000 to 4 294 967 295 (default setting: 9 999 999).

Discrete input data in Input Status 1 through 8 is applicable with firmware version V1.00 or higher.

■ DATA ALLOCATION 1

Master→Slave (R7M-PA8)			Slave (R7M-PA8)→Master		
Coil Status (0X)	Unused		Input Status (1X)	1 through 8	Discrete input data (V1.00 or higher)
	17 through 32	Extension output unit data		9 through 16	Unused
Holding Register (4X)				17 through 32	Extension input unit data
	1	CH 0 Preset value (upper)	Input Register (3X)	1	CH 0 Parameter data (upper)
	2	CH 0 Preset value (lower)		2	CH 0 Parameter data (lower)
	3	CH 1 Preset value (upper)		3	CH 1 Parameter data (upper)
	4	CH 1 Preset value (lower)		4	CH 1 Parameter data (lower)
	5	CH 2 Preset value (upper)		5	CH 2 Parameter data (upper)
	6	CH 2 Preset value (lower)		6	CH 2 Parameter data (lower)
	7	CH 3 Preset value (upper)		7	CH 3 Parameter data (upper)
	8	CH 3 Preset value (lower)		8	CH 3 Parameter data (lower)
	9	CH 4 Preset value (upper)		9	CH 4 Parameter data (upper)
	10	CH 4 Preset value (lower)		10	CH 4 Parameter data (lower)
	11	CH 5 Preset value (upper)		11	CH 5 Parameter data (upper)
	12	CH 5 Preset value (lower)		12	CH 5 Parameter data (lower)
	13	CH 6 Preset value (upper)		13	CH 6 Parameter data (upper)
	14	CH 6 Preset value (lower)		14	CH 6 Parameter data (lower)
	15	CH 7 Preset value (upper)		15	CH 7 Parameter data (upper)
	16	CH 7 Preset value (lower)		16	CH 7 Parameter data (lower)
	17	CH 0 Return value write data (upper)		17	CH 0 Return value read data (upper)
	18	CH 0 Return value write data (lower)		18	CH 0 Return value read data (lower)
	19	CH 1 Return value write data (upper)		19	CH 1 Return value read data (upper)
	20	CH 1 Return value write data (lower)		20	CH 1 Return value read data (lower)
	21	CH 2 Return value write data (upper)		21	CH 2 Return value read data (upper)
	22	CH 2 Return value write data (lower)		22	CH 2 Return value read data (lower)
	23	CH 3 Return value write data (upper)		23	CH 3 Return value read data (upper)
	24	CH 3 Return value write data (lower)		24	CH 3 Return value read data (lower)
	25	CH 4 Return value write data (upper)		25	CH 4 Return value read data (upper)
	26	CH 4 Return value write data (lower)		26	CH 4 Return value read data (lower)
	27	CH 5 Return value write data (upper)		27	CH 5 Return value read data (upper)
	28	CH 5 Return value write data (lower)		28	CH 5 Return value read data (lower)
	29	CH 6 Return value write data (upper)		29	CH 6 Return value read data (upper)
	30	CH 6 Return value write data (lower)		30	CH 6 Return value read data (lower)
	31	CH 7 Return value write data (upper)		31	CH 7 Return value read data (upper)
	32	CH 7 Return value write data (lower)		32	CH 7 Return value read data (lower)
	33	CH 0 Max. value write data (upper)		33	CH 0 Max. value read data (upper)
	34	CH 0 Max. value write data (lower)		34	CH 0 Max. value read data (lower)
	35	CH 1 Max. value write data (upper)		35	CH 1 Max. value read data (upper)
	36	CH 1 Max. value write data (lower)		36	CH 1 Max. value read data (lower)
	37	CH 2 Max. value write data (upper)		37	CH 2 Max. value read data (upper)
	38	CH 2 Max. value write data (lower)		38	CH 2 Max. value read data (lower)
	39	CH 3 Max. value write data (upper)		39	CH 3 Max. value read data (upper)
	40	CH 3 Max. value write data (lower)		40	CH 3 Max. value read data (lower)
	41	CH 4 Max. value write data (upper)		41	CH 4 Max. value read data (upper)
	42	CH 4 Max. value write data (lower)		42	CH 4 Max. value read data (lower)
	43	CH 5 Max. value write data (upper)		43	CH 5 Max. value read data (upper)
	44	CH 5 Max. value write data (lower)		44	CH 5 Max. value read data (lower)
	45	CH 6 Max. value write data (upper)		45	CH 6 Max. value read data (upper)
	46	CH 6 Max. value write data (lower)		46	CH 6 Max. value read data (lower)
	47	CH 7 Max. value write data (upper)		47	CH 7 Max. value read data (upper)
48	CH 7 Max. value write data (lower)		48	CH 7 Max. value read data (lower)	

EXTERNAL DIMENSIONS unit: mm (inch)

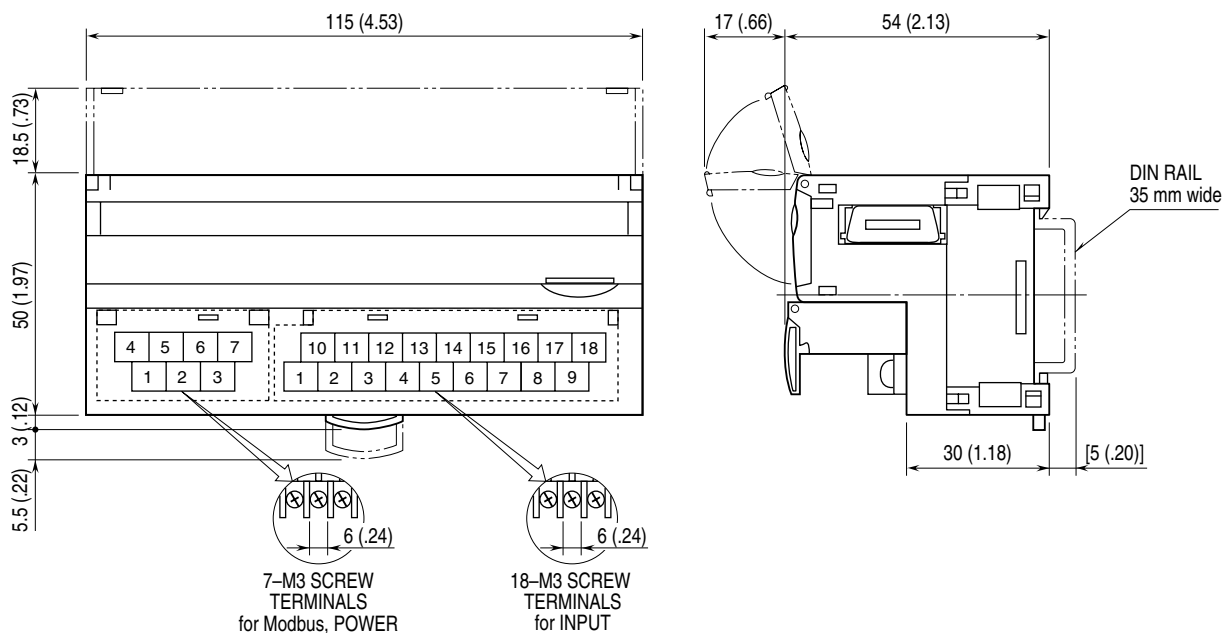

CONNECTION DIAGRAM

Connect the unit as in the diagram below.

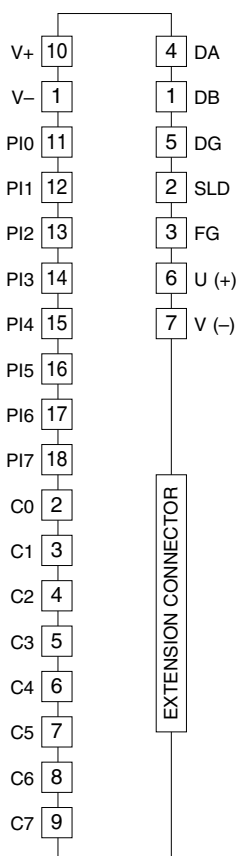

Input Connection Examples

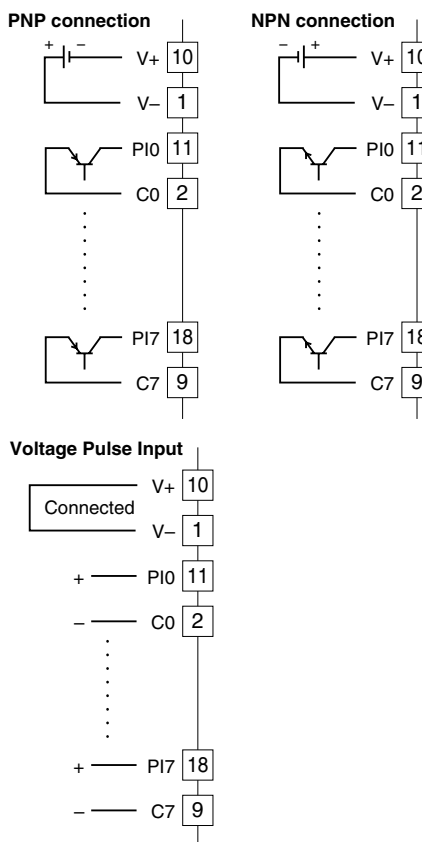

COMMUNICATION CABLE CONNECTIONS

■ MASTER CONNECTION

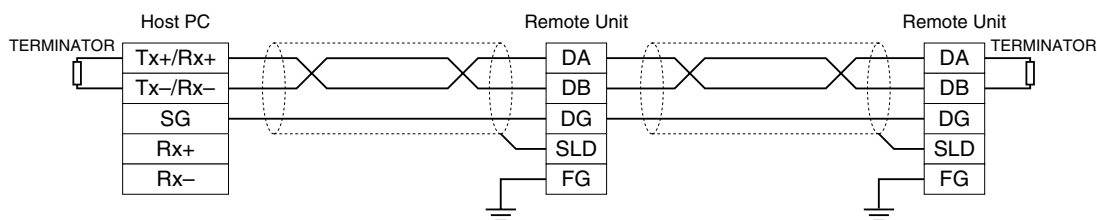

Be sure to connect the terminating resistor included in the product package to the unit at both ends of transmission line.
The terminator must be connected across DA and DB.
The Host PC can be located other than at the extreme ends of transmission line.

WIRING INSTRUCTIONS

■ SCREW TERMINAL

Torque: 0.5 N·m

■ SOLDERLESS TERMINAL

Refer to the drawing below for recommended ring tongue terminal size. Spade tongue type is also applicable.

Applicable wire size: 0.25 to 1.65 mm² (AWG 22 to 16)

Recommended manufacturer: Japan Solderless Terminal MFG. Co., Ltd, Nichifu Co., Ltd

