

STRAIN GAUGE INPUT MODULE, 2 points

(High-speed Link System, with monitor output)

MODEL R7HL-LC2

BEFORE USE

Thank you for choosing M-System. Before use, please check contents of the package you received as outlined below.

If you have any problems or questions with the product, please contact M-System's Sales Office or representatives.

■ PACKAGE INCLUDES:

Strain gauge input module.....(1)

■ MODEL NO.

Confirm Model No. marking on the product to be exactly what you ordered.

■ INSTRUCTION MANUAL

This manual describes necessary points of caution when you use this product, including installation, connection and basic maintenance procedures.

POINTS OF CAUTION

■ CONFORMITY WITH EU DIRECTIVE

- Use dual-shield cables (Shinko Seisen Industry Model ZHY262 PBA) for the network. If it is not sufficient, use a ferrite core (Kitagawa Industries Model GRFC-13) for the network cable.
- The equipment must be mounted inside the instrument panel of a metal enclosure.
- The actual installation environments such as panel configurations, connected devices, connected wires, may affect the protection level of this unit when it is integrated in a panel system. The user may have to review the CE requirements in regard to the whole system and employ additional protective measures to ensure the CE conformity.

■ POWER INPUT RATING & OPERATIONAL RANGE

- Locate the power input rating marked on the product and confirm its operational range as indicated below:
24V DC rating: 24V \pm 10%, approx. 150mA

■ GENERAL PRECAUTIONS

- Before you remove the unit or mount it, turn off the power supply and input signal for safety.
- DO NOT set the switches on the module while the power is supplied. The switches are used only for maintenance without the power.

■ ENVIRONMENT

- Indoor use.
- When heavy dust or metal particles are present in the air, install the unit inside proper housing with sufficient ventilation.
- Do not install the unit where it is subjected to continuous vibration. Do not subject the unit to physical impact.
- Environmental temperature must be within -10 to +55°C (14 to 131°F) with relative humidity within 30 to 90% RH in order to ensure adequate life span and operation.

■ WIRING

- Do not install cables close to noise sources (relay drive cable, high frequency line, etc.).
- Do not bind these cables together with those in which noises are present. Do not install them in the same duct.

■ AND

- The unit is designed to function as soon as power is supplied, however, a warm up for 10 minutes is required for satisfying complete performance described in the data sheet.

COMPONENT IDENTIFICATION

■ SIDE VIEW

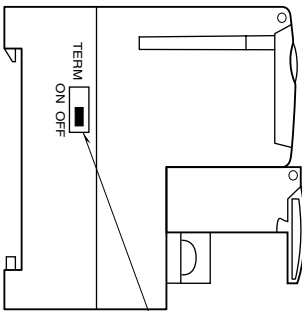

Terminating Resistor SW

■ FRONT VIEW

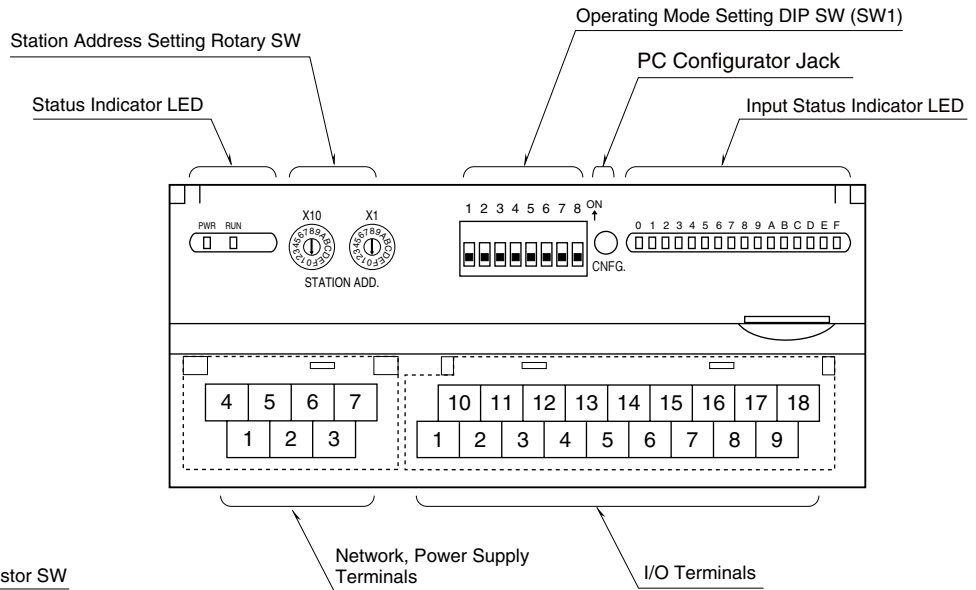

■ STATUS INDICATOR LED

ID	COLOR	FUNCTION
PWR	Green	Turns on when the internal 5V is supplied normally.
RUN	Green	Turns on when the refresh data is received normally.

■ INPUT STATUS INDICATOR LED

Each input status indicator LED turns ON when:

- 0 : Input 0 automatic zero correction is set
- 1 : Input 0 zero adjustment is set
- 2 : Input 0 span adjustment is set
- 5 : Input 0 underflow is detected
- 6 : Input 0 normal input is received
- 7 : Input 0 overflow is detected
- 8 : Input 1 automatic zero correction is set
- 9 : Input 1 zero adjustment is set
- A : Input 1 span adjustment is set
- D : Input 1 underflow is detected
- E : Input 1 normal input is received
- F : Input 1 overflow is detected

Note 1. LED 3, 4, B and C are not used.

Note 2. Not exceeding -1.0% of input is underflow, not lower than +101.0% of input is overflow.

■ STATION ADDRESS

The left switch determines the sixteenths place digit, while the right switch does the ones place digit of the address.

The data allocation is 2.

(Range: 01H to 3EH)



Station Address Setting (x1)

Station Address Setting (x16)

■ OPERATING MODE

(*) Factory setting

• Excitation Voltage (SW1-2)

SW1-2	EXCITATION VOLTAGE
OFF	5 V (*)
ON	2.5 V

• Lowpass Filter (SW1-3)

SW1-3	LOWPASS FILTER
OFF	2 kHz (/F2K) / 1 Hz (/F1) (*)
ON	2 Hz

• Averaging (SW1-4, 1-5, 1-6, 1-7)

SW1-4	SW1-5	SW1-6	SW1-7	AVERAGING
OFF	OFF	OFF	OFF	2 samples (*)
ON	OFF	OFF	OFF	4 samples
OFF	ON	OFF	OFF	8 samples
ON	ON	OFF	OFF	16 samples
OFF	OFF	ON	OFF	32 samples
ON	OFF	ON	OFF	64 samples
OFF	ON	ON	OFF	128 samples
ON	ON	ON	OFF	256 samples
OFF	OFF	OFF	ON	512 samples
ON	OFF	OFF	ON	1024 samples

• Transfer rate (SW1-8)

SW1-8	TRANSFER RATE
OFF	12 Mbps (*)
ON	6 Mbps

Note: Be sure to set unused SW1-1 to OFF.

■ TERMINATING RESISTOR

To use the terminating resistor, turn the switch ON, and OFF to invalidate.

(Factory setting OFF)

NETWORK, POWER SUPPLY TERMINAL ASSIGNMENT

• Full-duplex communication

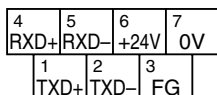

NO.	ID	FUNCTION, NOTES
1	TXD+	Network (slave, transmission +)
2	TXD-	Network (slave, transmission -)
3	FG	FG
4	RXD+	Network (master, transmission +)
5	RXD-	Network (master, transmission -)
6	+24V	Power input (24V DC)
7	0V	Power input (0V)

• Half-duplex communication

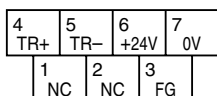

NO.	ID	FUNCTION, NOTES
1	NC	No connection
2	NC	No connection
3	FG	FG
4	TR+	Network
5	TR-	Network
6	+24V	Power input (24V DC)
7	0V	Power input (0V)

I/O TERMINAL ASSIGNMENT

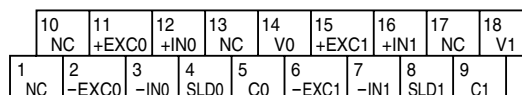

NO.	ID	FUNCTION	NO.	ID	FUNCTION
1	NC	No connection	10	NC	No connection
2	-EXC0	Exc. 0 -	11	+EXC0	Exc. 0 +
3	-IN0	Input 0 -	12	+IN0	Input 0 +
4	SLD0	Shield 0	13	NC	No connection
5	C0	Voltage output 0 -	14	V0	Voltage output 0 +
6	-EXC1	Exc. 1 -	15	+EXC1	Exc. 1 +
7	-IN1	Input 1 -	16	+IN1	Input 1 +
8	SLD1	Shield 1	17	NC	No connection
9	C1	Voltage output 1 -	18	V1	Voltage output 1 +

PC CONFIGURATOR

With configurator software, settings shown below are available.
Refer to the software manual of R7CON for detailed operation.

CHANNEL INDIVIDUAL SETTING

PARAMETER	AVAILABLE RANGE	DEFAULT SETTING
Zero scale	-32000 to +32000	0
Full scale	-32000 to +32000	10000
Bias	-320.00 to +320.00	0.00
Gain	-3.2000 to +3.2000	1.0000
Load ratio	10.00 to 100.00	100.00

TERMINAL CONNECTIONS

Connect the unit as in the diagram.

EXTERNAL DIMENSIONS unit: mm (inch)

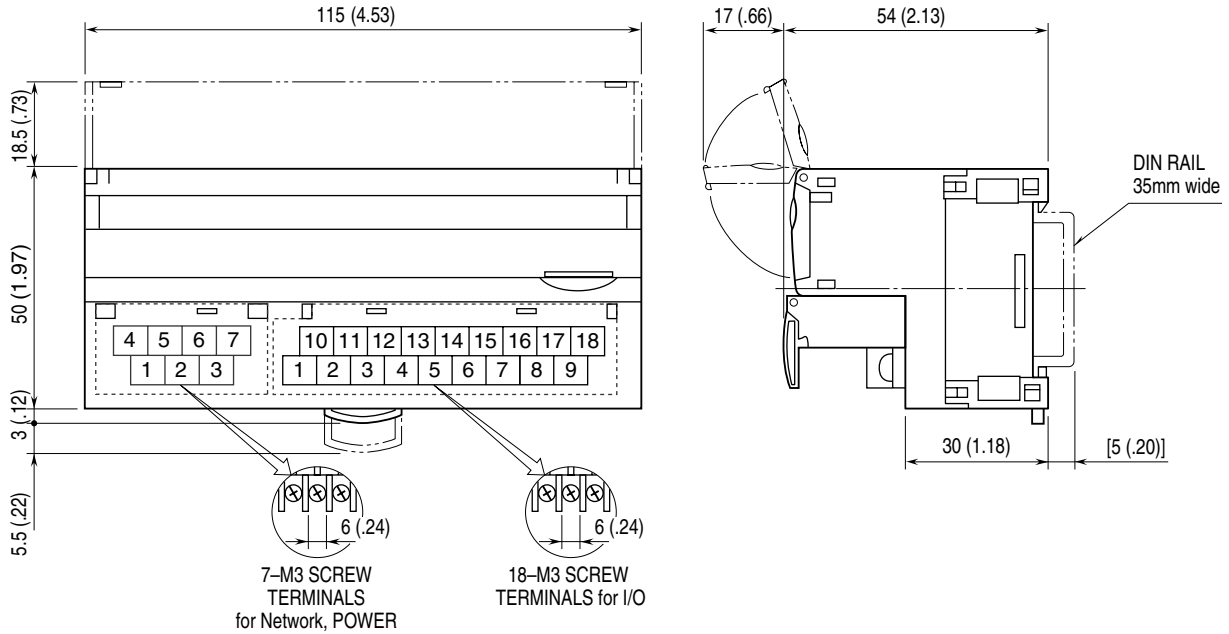

CONNECTION DIAGRAM

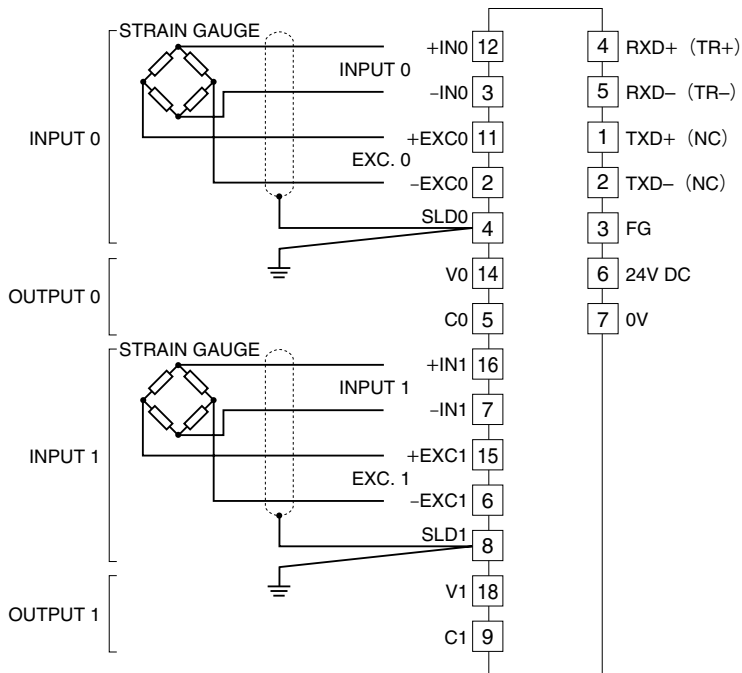

Note 1: Terminal numbers in parentheses are for half-duplex communication model.

Note 2: In order to improve EMC performance, bond the FG terminal to ground.

Caution: FG terminal is NOT a protective conductor terminal.

WIRING INSTRUCTIONS

■ SCREW TERMINAL

Torque: 0.5 N·m

■ SOLDERLESS TERMINAL

Refer to the drawing below for recommended ring tongue terminal size. Spade tongue type is also applicable.

Recommended solderless terminal:

• Communication cables

Applicable wire size: 0.2 to 0.5 mm² (AWG 26 to 22)

Recommended manufacturer: Japan Solderless Terminal MFG. Co., Ltd.

• Others

Applicable wire size: 0.25 to 1.65 mm² (AWG 22 to 16)

Recommended manufacturer: Japan Solderless Terminal MFG. Co., Ltd. or Nichifu Co., Ltd.

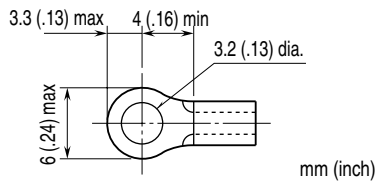

COMMUNICATION CABLE CONNECTIONS

■ MASTER CONNECTION

• Full-duplex communication

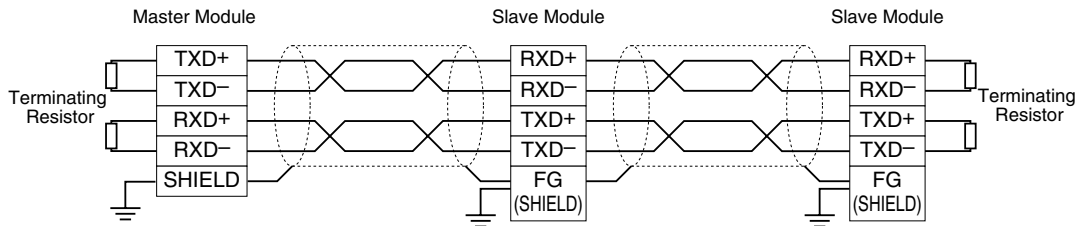

• Half-duplex communication

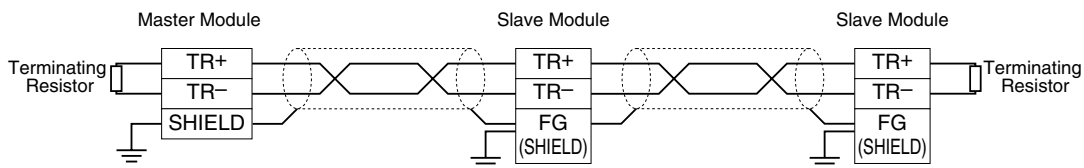

Note: Be sure to turn ON the switch of the terminating resistor located at both ends of the modules.

I/O DATA DESCRIPTIONS

■ STRAIN GAUGE INPUT

• Di

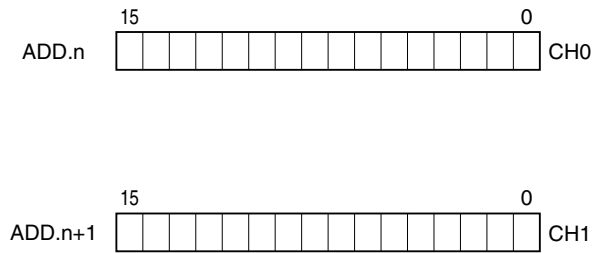

• Do

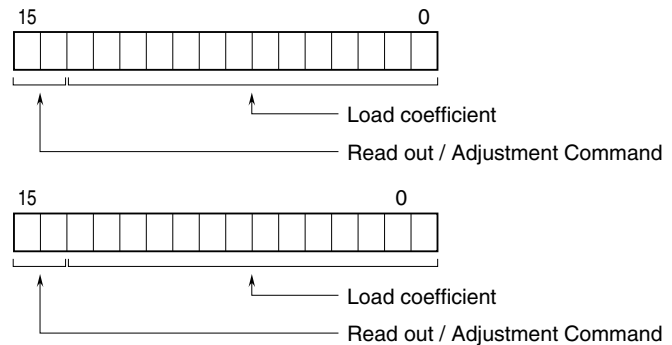

The value in the input range corresponding to -10000 to $+10000$ is represented in 16 bits binary data. Address allocation for full-duplex and half-duplex communication is same.

■ LOAD COEFFICIENT

It is available to configure the load coefficient to 0 or the range of 1000 (10.00%) to 10000 (100.00%). The load coefficient: 0 is equivalent to 100.00%.

■ READ OUT / ADJUSTMENT COMMAND

Read out command and adjustment command for data are allocated to bit 14 and 15. The details of the commands are shown in the table below.

COMMAND	BIT 15	BIT 14
Read out data	0	0
Auto zero adjustment	0	1
Zero adjustment	1	0
Span adjustment	1	1

ADJUSTMENT PROCEDURE

Follow the adjustment procedure shown below.

DO NOT turn off the power during adjustment. Adjustment data may be corrupted and operation may be unable.

■ AUTO ZERO

Offset the input to '0'. Perform the auto zero after zero and span adjustment are finished. Follow the instruction below.

- 1) Set the sensor to the input state you want to give an offset.
- 2) Set the bit 15 of output data area to '0', bit 14 of output data area to '1'.
- 3) After completing, the input data becomes '4000H'.
- 4) After confirming that the input data is '4000H', be sure to write '0000H' and set data read out mode.

■ ZERO ADJUSTMENT

Adjust the zero of input. Follow the instruction below.

- 1) Apply 0% load to the sensor.
- 2) Set the bit 15 of output data area to '1', bit 14 of output data area to '0'.
- 3) After completing, the input data becomes '8000H'.
- 4) After confirming that the input data is '8000H', be sure to write '0000H' and set data read out mode.

■ SPAN ADJUSTMENT (ACTUAL LOAD ADJUSTMENT)

Adjust the span. Follow the instruction below.

- 1) Apply 100% load to the sensor.
- 2) Set the bit 15 of output data area to '1', bit 14 of output data area to '1'.
- 3) After completing, the input data becomes 'C000H'.
- 4) After confirming that the input data is 'C000H', be sure to write '0000H' and set data read out mode.

■ LOAD COEFFICIENT

Setting load coefficient enables to adjust without 100% actual load. Follow the instruction to set 20% load below.

- 1) Apply 20% load to the sensor.
- 2) Set 'C7D0H' to the output data area. Bit 15: 1, bit 14: 1, load coefficient: 2000 (7D0H, 20.00%).
- 3) After completing, the input data becomes configured output data 'C7D0H'.
- 4) After confirming that the input data is 'C7D0H', be sure to write '0000H' and set data read out mode.