

BEFORE USE

Thank you for choosing M-System. Before use, please check contents of the package you received as outlined below.

If you have any problems or questions with the product, please contact M-System's Sales Office or representatives.

■ PACKAGE INCLUDES:

Thermistor input module.....(1)
Terminating resistor (110 Ω, 0.5 W).....(1)

■ MODEL NO.

Confirm Model No. marking on the product to be exactly what you ordered.

■ INSTRUCTION MANUAL

This manual describes necessary points of caution when you use this product, including installation, connection and basic maintenance procedures.

POINTS OF CAUTION**■ POWER INPUT RATING & OPERATIONAL RANG**

- Locate the power input rating marked on the product and confirm its operational range as indicated below:
24V DC rating: 24V ±10%, approx. 95mA

■ GENERAL PRECAUTIONS

- Before you remove the unit or mount it, turn off the power supply and input signal for safety.
- DO NOT set the switches on the module while the power is supplied. The switches are used only for maintenance without the power.

■ ENVIRONMENT

- Indoor use.
- When heavy dust or metal particles are present in the air, install the unit inside proper housing with sufficient ventilation.
- Do not install the unit where it is subjected to continuous vibration. Do not subject the unit to physical impact.
- Environmental temperature must be within -10 to +55°C (14 to 131°F) with relative humidity within 30 to 90% RH in order to ensure adequate life span and operation.

■ WIRING

- Do not install cables close to noise sources (relay drive cable, high frequency line, etc.).
- Do not bind these cables together with those in which noises are present. Do not install them in the same duct.

■ AND

- The unit is designed to function as soon as power is supplied, however, a warm up for 10 minutes is required for satisfying complete performance described in the data sheet.

COMPONENT IDENTIFICATION

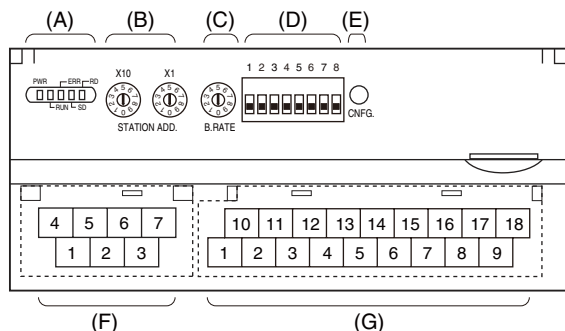

- (A) Status Indicator LED *1
- (B) Station Address Setting Rotary SW
- (C) Baud Rate Setting Rotary SW
- (D) Operating Mode Setting DIP SW (SW1)
- (E) PC Configurator Jack
- (F) CC-Link, Power Supply Terminals
- (G) Input Terminals

*1. Refer to 'Status Indicator LED' section for detailed information.

STATUS INDICATOR LED

ID	COLOR	FUNCTION
PWR	Red	Turns on when the internal 5V is supplied normally.
RUN	Red	Turns on when the refresh data is received normally.
ERR	Red	Turns on when the received data is abnormal.
SD	Red	Turns on when the module is transmitting.
RD	Red	Turns on when the module is receiving.

STATION ADDRESS

Station Address is selected between 1 and 64 in decimal. The left switch determines the tenth place digit, while the right switch does the ones place digit of the address.

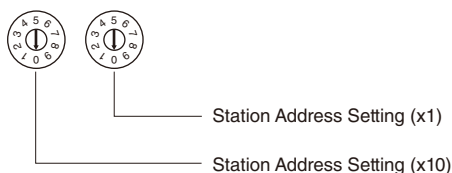

BAUD RATE

Baud Rate is selected with the rotary switch.

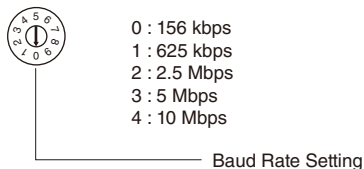

OPERATING MODE

(*) Factory setting

Extension (SW1-1, 1-2)

SW1-1	SW1-2	EXTENSION
OFF	OFF	No extension (*)
ON	OFF	Discrete input, 8 or 16 points
OFF	ON	Discrete output, 8 or 16 points

Conversion Rate (SW1-3) • Burnout (SW1-4)

SW1-3	CONVERSION RATE	SW1-4	BURNOUT
OFF	250 msec. (*)	OFF	Upscale (*)
ON	500 msec.	ON	Downscale

Note: Be sure to unused SW 1-5 through 1-8 to OFF.

POWER SUPPLY, CC-LINK TERMINAL ASSIGNMENT

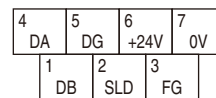

NO.	ID	FUNCTION, NOTES
1	DB	White
2	SLD	Shield
3	FG	FG
4	DA	Blue
5	DG	Yellow
6	+24V	Power input (24V DC)
7	0V	Power input (0V)

INPUT TERMINAL ASSIGNMENT

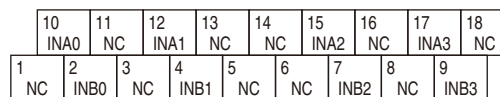

NO.	ID	FUNCTION	NO.	ID	FUNCTION
1	NC	No connection	10	INA0	Thermistor 0-A
2	INB0	Thermistor 0-B	11	NC	No connection
3	NC	No connection	12	INA1	Thermistor 1-A
4	INB1	Thermistor 1-B	13	NC	No connection
5	NC	No connection	14	NC	No connection
6	NC	No connection	15	INA2	Thermistor 2-A
7	INB2	Thermistor 2-B	16	NC	No connection
8	NC	No connection	17	INA3	Thermistor 3-A
9	INB3	Thermistor 3-B	18	NC	No connection

EXTENSION MODULE

Combinations with all extension modules are selectable.

INDICATOR LED

■ STATUS INDICATOR LED

PWR	RUN	ERR	SD *1	RD	STATUS *2
ON	ON	BL	BL	ON	Communicates normally with occasional CRC errors due to noise interference.
ON	ON	BL	BL	ON	Communicates normally but the Baud Rate and/or Station Address switches failed. ERR LED blinks approximately in 0.5 seconds intervals.
ON	ON	BL	BL	OFF	----
ON	ON	BL	OFF	ON	CRC error found in the received data. Unable to respond.
ON	ON	BL	OFF	OFF	----
ON	ON	OFF	BL	ON	Normal communication
ON	ON	OFF	BL	OFF	----
ON	ON	OFF	OFF	ON	Unable to receive data addressed to the station.
ON	ON	OFF	OFF	OFF	----
ON	OFF	BL	BL	ON	Performs the interval-timed responses but CRC error found in receiving the refresh data.
ON	OFF	BL	BL	OFF	----
ON	OFF	BL	OFF	ON	CRC error found in the data addressed to the station.
ON	OFF	BL	OFF	OFF	----
ON	OFF	OFF	BL	ON	Link is not started.
ON	OFF	OFF	BL	OFF	----
ON	OFF	OFF	OFF	ON	No data addressed to the station. Or unable to receive data addressed to the station due to noise interference. (Missing parts of the data sent from the master)
ON	OFF	OFF	OFF	OFF	Unable to receive data due to wire breakdown
ON	OFF	ON	OFF	ON/OFF	Faulty Baud Rate and/or Station Address setting
OFF	OFF	OFF	OFF	OFF	Power input removed. Or power supply failure.

OFF = OFF, ON = ON, BL = Blinking

*1. SD LED may look not blinking but ON with high baud rate and fewer connected modules.

*2. LEDs indicated with "----" in STATUS rarely occurs in normal operation (LED failure or the like as possible cause).

PC CONFIGURATOR

With configurator software, settings shown below are available.

Refer to the software manual of R7CON for detailed operation.

■ INTERFACE MODULE SETTING

PARAMETER	AVAILABLE RANGE	DEFAULT SETTING
Communication Timeout	0.0 – 3276.7 (sec.)	1.0 (sec.)

■ CHANNEL INDIVIDUAL SETTING

PARAMETER	AVAILABLE RANGE	DEFAULT SETTING
Temp Unit	C, F, K	C
Zero scale	-32000 to +32000	0
Full scale	-32000 to +32000	10000
Bias	-320.00 to +320.00	0.00
Gain	-3.2000 to +3.2000	1.0000
Zero temp	-40 to +90 (degC)	0.00 (degC)
Full temp	-40 to +90 (degC)	0.00 (degC)

■ EXTENSION MODULE SETTING

PARAMETER	AVAILABLE RANGE	DEFAULT SETTING
Output Hold/Clear	Output Hold Output Clear	Output Hold

TERMINAL CONNECTIONS

Connect the unit as in the diagram below.

EXTERNAL DIMENSIONS unit: mm (inch)

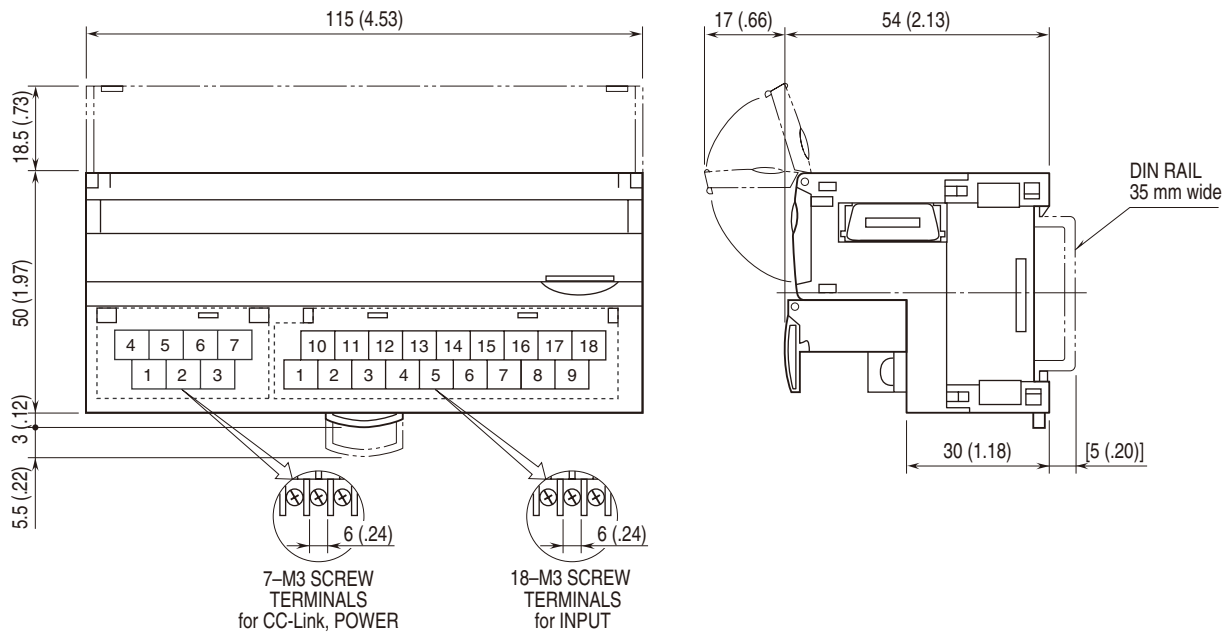

CONNECTION DIAGRAM

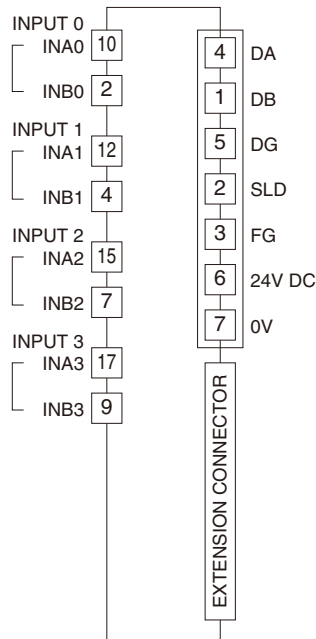

Caution: FG terminal is NOT a protective conductor terminal.

Input Connection Example

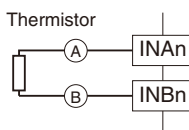

COMMUNICATION CABLE CONNECTIONS

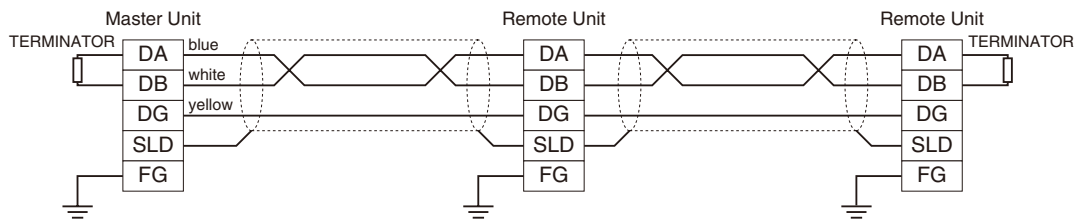

Be sure to connect the terminating resistor included in the product package to the unit at both ends of communication line.
 The terminator must be connected across DA and DB.
 The Master Unit can be located other than at the extreme ends of communication line.

DATA ALLOCATION

■ ANALOG INPUT

Interval-timed Response (X)	
RW _{rn} +0	Analog input 0
+1	Analog input 1
+2	Analog input 2
+3	Analog input 3

Refresh Data (Y)	
RW _{wn} +0	Unused
+1	Unused
+2	Unused
+3	Unused

• Without Extension Module

Interval-timed Response (X)	
0	RX(n+0)F to RX(n+0)0 (Status)
F	Reserved
1F	

Refresh Data (Y)	
0	
F	Unused
1F	

• With Extension Module R7C-EA16

Interval-timed Response (X)	
0	RX(n+0)F to RX(n+0)0 (R7C-EA16)
F	Reserved
1F	

Refresh Data (Y)	
0	
F	Unused
1F	

• With Extension Module R7C-EC16x

Interval-timed Response (X)	
0	RX(n+0)F to RX(n+0)0 (Status)
F	Reserved
1F	

Refresh Data (Y)	
0	
F	RY(n+0)F to RY(n+0)0 (R7C-EC16x)
1F	Unused

I/O DATA DESCRIPTIONS

ANALOG INPUT



16-bit binary data
Negative values represented in 2's complements

DISCRETE I/O

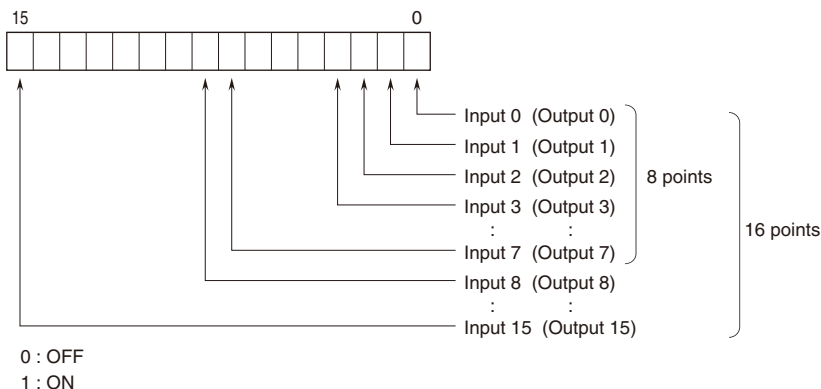

STATUS

Analog input module without extension module can show input status of each channel.

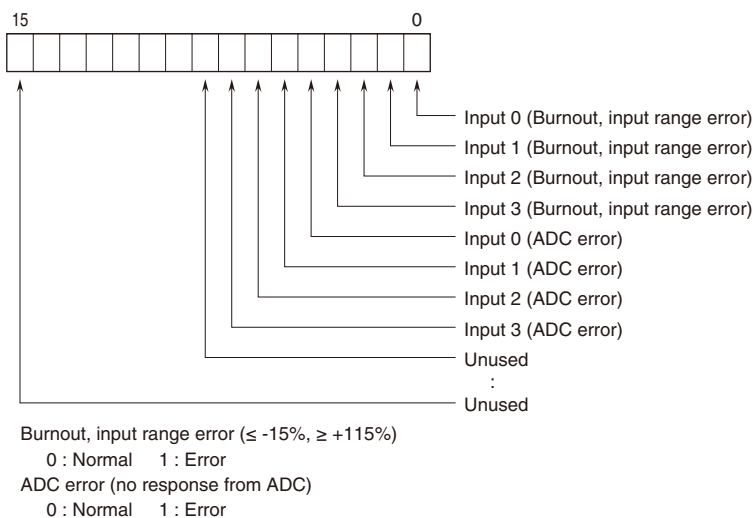

WIRING INSTRUCTIONS

SCREW TERMINAL

Torque: 0.5 N·m

SOLDERLESS TERMINAL

Refer to the drawing below for recommended ring tongue terminal size. Spade tongue type is also applicable.

Applicable wire size: 0.25 to 1.65 mm² (AWG 22 to 16)

Recommended manufacturer: Japan Solderless Terminal MFG. Co., Ltd, Nichifu Co., Ltd

